



CE TEST REPORT

for

BALANCE CHARGER

Model: VTE600

Prepared for: VAPEX TECHNOLOGY LIMITED
Room 1103, 11/F, Hang Seng Mongkok Building, 677 Nathan Road,
Mongkok, Kowloon Hong Kong

Prepared by: Shenzhen ZJT Testing Technology Co.,Ltd
6F, Henglin Building, Baoyuan Road, Xixiang Street, Baoan
District, Shenzhen

TEL: +86-0755-29472739

FAX: +86-0755-29472539

Report Number: ZJT131014003E-1

Date of Test: Oct.14~21, 2013

Date of Issue: Oct.21, 2013

Tested By

Beryl Zhao

Beryl Zhao

Reviewed By



Jack Kang

The results detailed in this test report relate only to the specific sample(s) tested. It is the Application's responsibility to ensure that all production units are manufactured with equivalent EMC characteristics. This report is not to be reproduced except in full, without written approval from ZJT Testing Technology.



Table of contents

1.0	General Details	3
1.1	Test Lab Details.....	3
1.2	Applicant Details.....	3
1.3	Description of EUT	3
1.4	Submitted Sample.....	3
1.5	Test Duration.....	3
2.0	List of Measurement Equipment.....	4
3.0	Technical Details.....	6
3.1	Summary of Test Results.....	6
3.2	Test Standards.....	6
3.3	Performance Criteria.....	6
3.4	Test standards and Results Summary Tables.....	7
3.5	Measurement Uncertainty.....	7
4.0	Electromagnetic Interference Test results.....	8
4.1	Power Line Conducted Emission Test.....	8
4.2	Telecommunication ports Conducted Emission Test.....	12
4.3	Radiated Emission test.....	14
4.4	Harmonic Current Emissions.....	18
4.5	Flicker and Voltage Fluctuation.....	19
5.0	Immunity Test.....	20
5.1	Electrostatic Discharge.....	20
5.2	RF field strength susceptibility.....	21
5.3	Electrical Fast Transient/Burst.....	22
5.4	Surge test.....	23
5.5	Conducted Immunity test.....	24
5.6	Power-Frequency magnetic field test.....	25
5.7	Voltage Dips/Interruptions immunity test.....	26
6.0	CE label.....	27
7.0	Photos of Test.....	28
8.0	Photos of the EUT	29



1.0 General Details

1.1 Test Lab Details

Name : Shenzhen ZJT Testing Technology Co.,Ltd
Address: 6F, Henglin Building, Baoyuan Road, Xixiang Street, Baoan District, Shenzhen
Telephone: +86-0755-29472739
Fax: +86-0755-29472539

1.2 Applicant Details

Applicant: VAPEX TECHNOLOGY LIMITED
Address: Room 1103, 11/F, Hang Seng Mongkok Building, 677 Nathan Road, Mongkok, Kowloon Hong Kong
Tel: --
Fax: --

Manufacturer: VAPEX TECHNOLOGY LIMITED.
Address: Bldg 30-33, Tongfucun Ind.Park, Dalang, Longhua, Shenzhen, 518109, Guangdong, China
Telephone: --
Fax: --

1.3 Description of EUT

Product: BALANCE CHARGER
Model No.: VTE600
Additional Model No.: --
Brand Name: VP
Rating: --

1.4 Submitted Sample

1 Sample

1.5 Test Duration

2013-10-14 to 2013-10-21



2.0 List Test Equipments					
Name	Model No.	Serial No.	Manufacturer	Date of Cal.	Due Date
Conducted emission					
EMI Test Receiver	ESCS30	100139	R&S	2013-07-25	2014-07-24
LISN	LS16C	16010222119	AFJ	2013-07-25	2014-07-24
Radiated emission					
EMI Test Receiver	ESCS30	100139	R&S	2013-07-25	2014-07-24
Spectrum Analyzer	FSEM	1079.8500.30	R&S	2013-07-25	2014-07-24
Amplifier	8447D	2727A05017	H.P.	2013-07-25	2014-07-24
Antenna	VULB9163	N/A	SCHWARZBECK	2013-07-25	2014-07-24
Amplifier	EM30265	07032613	EM Electronics Corporation	2013-07-25	2014-07-24
Positioning Controller	CC-C-1F	MF7802140	C & C LAB	2013-07-25	2014-07-24
Harmonic & Flicker					
Harmonics Flicker Test System	PACS-1	72305	CI	2013-07-25	2014-07-24
5K VA AC Power source	5001iX	56060	CI	2013-07-25	2014-07-24
Electrostatic Discharge					
Electostatic Discharge Generator	ESD61002AG	PR12092502	Prima	2013-07-25	2014-07-24
Continuous radiated disturbances					
Signal Generator	2022D	119246/003	Maconi	2013-07-25	2014-07-24
Power Amplifier	A00181-1000	9801-112	M2S	2013-07-25	2014-07-24
Power Amplifier	AC8113/ 800-250A	9801-179	M2S	2013-07-25	2014-07-24
Power Antenna	CBL6140A	1204	SCHAFFNER	2013-07-25	2014-07-24
EFT/Surge/Dip					
Fast Transient Burst Simulator	EFT61004BG	PR12074375	Prima	2013-07-25	2014-07-24
Lightning Surge Generator	SUG61005BG	PR12125534	Prima	2013-07-25	2014-07-24
CYCLE SAG SIMULATOR	DRP61011AG	PR12106201	Prima	2013-07-25	2014-07-24
Continuous conducted disturbances					
Signal Generator	2022D	119246/003	Maconi	2013-07-25	2014-07-24
Power Amplifier	A00181-1000	9801-112	M2S	2013-07-25	2014-07-24
CDN	M3-8016	003683	MEB	2013-07-25	2014-07-24
Power-frequency Magnetic field					
Continuous Wave Simulator	UCS 500 M4	0304-42	EM TEST	2013-07-25	2014-07-24
Power Source Network	MV 2616	0104-14	EM TEST	2013-07-25	2014-07-24



Current Transformer	MC2630	--	EM TEST	2013-07-25	2014-07-24
Magnetic Coil	MS100	0304-42	EM TEST	2013-07-25	2014-07-24

N/A=not applicable



3.0 Technical Details

3.1 Investigations Requested

Perform Electromagnetic Interference [EMI] & Electromagnetic Susceptibility [EMS] tests for CE Marking

3.2 Test Standards

EN 55022: 2010	Limits and methods of measurement of radio disturbance characteristics for information technology equipment
EN 61000-3-2:2006+A2:2009	Electromagnetic compatibility(EMC)- Part 3-2:Limits-Limits for harmonic current emissions(equipment input current $\leq 16A$ per phase)
EN 61000-3-3:2008	Electromagnetic compatibility (EMC)- Part 3-3:Limits-Limitation of voltage changes, Voltage fluctuations and flicker in public low-voltage supply systems, for equipment with rated current $\leq 16A$ per phase and not subject to conditional connection
EN 55024: 2010	Electromagnetic Compatibility Generic Immunity Standard, Part 1: Residential, Commercial and Light Industry.

3.3 Performance Criteria

- Criterion A During and after the test the EUT shall continue to operate as intended without operator intervention. No degradation of performance or loss of function is allowed.
- Criterion B During the test, degradation of performance is allowed. However, no change of operating state or stored data is allowed to persist after the test.
- Criterion C During and after testing, temporary loss of function is allowed, provided the function is self-recoverable, or can be restored by the operation of the controls or cycling of the power to the EUT by the user in accordance with the manufacturer' instructions.
Functions, and/or information stored in non-volatile memory, or protected by a battery backup, shall not be lost.



3.4 Test standards and Results Summary Tables

Test Condition	Test Requirement	Test Method	Test Result
EMISSION Results Summary			
Conducted Emission on AC Mains, 150KHz to 30MHz	EN 55022: 2010	EN 55022: 2010	N/A
Conducted Emission on at telecommunication ports, 150KHz to 30MHz	EN 55022: 2010	EN 55022: 2010	N/A
Radiated Emissions, 30MHz to 1GHz	EN 55022: 2010	EN 55022: 2010	Pass
Harmonic Emissions on AC supply	EN 61000-3-2:2006+A2:2009	EN 61000-3-2:2006+A2:2009	N/A
Voltage fluctuations on AC supply	EN 61000-3-3:2008	EN 61000-3-3:2008	N/A
IMMUNITY Results Summary			
Electrostatic Discharge	EN 55024: 2010	EN 61000-4-2: 2009	Pass
RF field strength susceptibility	EN 55024: 2010	EN 61000-4-3: 2010	Pass
Electrical Fast transients /Burst Immunity	EN 55024: 2010	EN 61000-4-4:2004+A1:2010	N/A
Surge	EN 55024: 2010	EN 61000-4-5: 2006	N/A
Conducted susceptibility	EN 55024: 2010	EN 61000-4-6: 2009	N/A
Power-frequency Magnetic Field	EN 55024: 2010	EN 61000-4-8:2010	N/A
Dips/Voltage Interruption Variation	EN 55024: 2010	EN 61000-4-11: 2004	N/A

Note: N/A=Not applicable

3.5 Measurement Uncertainty (95% confidence levels, k=2)

No.	Item	MU
1.	Temperature	$\pm 0.1^{\circ}\text{C}$
2.	Humidity	$\pm 1.0\%$
3.	Spurious emissions, conducted	$\pm 3.70\text{dB}$
4.	All emissions, radiated	$\pm 4.50\text{dB}$

4.0 Electromagnetic Interference Test results

4.1 Power Line Conducted Emission Test

4.1.1 Schematics of the test

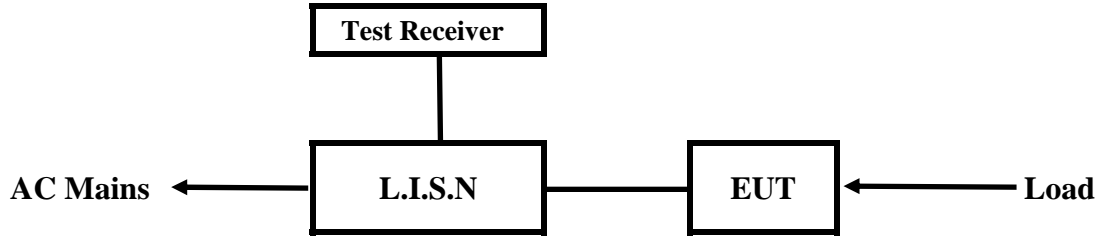

EUT: Equipment Under Test

4.1.2 Test Method and test Procedure

The test was performed in accordance with EN 55022: 2010

Test Voltage: 230V~, 50Hz

Block diagram of Test setup

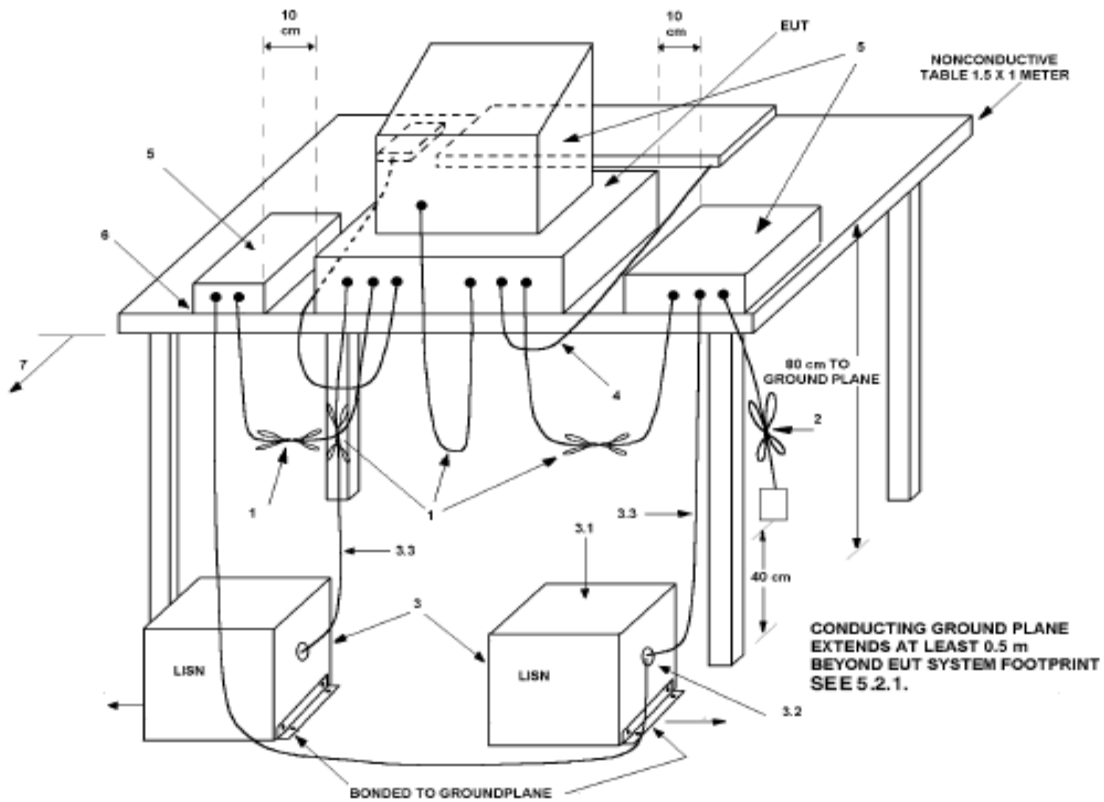



4.1.3 EUT Operating Condition

Operating condition is according to EN 55022:2010
 Setup the EUT and simulators as shown on the following

4.1.4 Test Equipment

Please refer to the Section 2

4.1.5 Power line conducted Emission Limit

Frequency(MHz)	Class A Limits (dBµV)		Class B Limits (dBµV)	
	Quasi-peak Level	Average Level	Quasi-peak Level	Average Level
0.15 ~ 0.50	79.0	66.0	66.0~56.0*	56.0~46.0*
0.50 ~ 5.00	73.0	60.0	56.0	46.0
5.00 ~ 30.00	73.0	60.0	60.0	50.0

- Notes: 1. *Decreasing linearly with logarithm of frequency.
 2. The tighter limit shall apply at the transition frequencies

4.1.6 Photo documentation of the test set-up

Please refer to the Section 7

4.1.7 Test specification:

Environmental conditions: Temperature: 23° C Humidity: 51% Atmospheric pressure: 103kPa

Frequency range: 0.15 MHz – 30 MHz

4.1.8 Test result

Min. limit margin --

The requirements are FULFILLED

Remarks: According to the EN 55022:2010



A Conducted Emission on Live Terminal of the power line (150kHz to 30MHz)

EUT Description: --
Operation Mode: --
Tested By: --
Test date: --

Start Frequency Stop Frequency Step IF BW Detector Final M-Time
0.15MHz 30MHz 4.5KHz 10KHz QP+AV 1s

Frequency (MHz)	Reading(dBμV)				Limit (dBμV)	
	Live		Neutral		Quasi-peak	Average
	Quasi-peak	Average	Quasi-peak	Average		
--	--	--	--	--	--	--
--	--	--	--	--	--	--
--	--	--	--	--	--	--
--	--	--	--	--	--	--



B Conducted Emission on Neutral Terminal of the power line (150kHz to 30MHz)

EUT Description: --
Operation Mode: --
Tested By: --
Test date: --

Start Frequency Stop Frequency Step IF BW Detector Final M-Time
 0.15MHz 30MHz 4.5KHz 10KHz QP+AV 1s

Frequency (MHz)	Reading(dB μ V)				Limit (dB μ V)	
	Live		Neutral		Quasi-peak	Average
	Quasi-peak	Average	Quasi-peak	Average		
--	--	--	--	--	--	--
--	--	--	--	--	--	--
--	--	--	--	--	--	--
--	--	--	--	--	--	--

Note: Due to DC Operation, this test item is not applicable.

4.2 Telecommunication ports Conducted Emission Test

4.2.1 Test Method: The test was performed in accordance with EN 55022: 2010

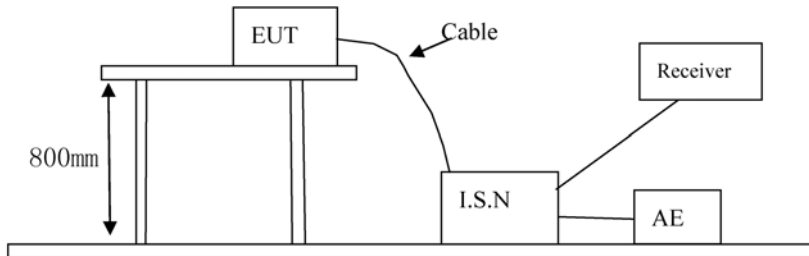

4.2.2 EUT Operating Condition

Operating condition is according to EN 55022: 2010

4.2.3 Test Equipment

Please refer to the Section 2

4.2.4 Power line conducted Emission Limit

Frequency(MHz)	Class A Limits (dBμV)		Class B Limits (dBμV)	
	Quasi-peak Level	Average Level	Quasi-peak Level	Average Level
0.15 ~ 0.50	97 to 87	84 to 74	84 to 74	74 to 64
0.50 ~ 30.00	87	74	74	64

- Notes: 1. *Decreasing linearly with logarithm of frequency.
2. The tighter limit shall apply at the transition frequencies

4.2.5 Test specification:

Environmental conditions: Temperature: 23° C Humidity: 50% Atmospheric pressure: 103kPa

Frequency range: 0.15 MHz – 30 MHz

4.2.6 Test result

Min. limit margin --

The requirements are FULFILLED

Remarks: According to the EN 55022:2010



A Conducted Emission on Telecommunication port (150kHz to 30MHz)

EUT Description: --

Operation Mode: --

Tested By: --

Test date: --

Start Frequency	Stop Frequency	Step	IF BW	Detector	Final M-Time
0.15MHz	30MHz	4.5KHz	10KHz	QP+AV	1s

Frequency (MHz)	Port	Reading(dBμA)		Limit(dBμA)	
		Quasi-peak	Average	Quasi-peak	Average

4.3 Radiated Emission Test

4.3.1 Schematics of the test



4.3.2 Test Method: The test was performed in accordance with EN 55022: 2010

Block diagram of Test setup

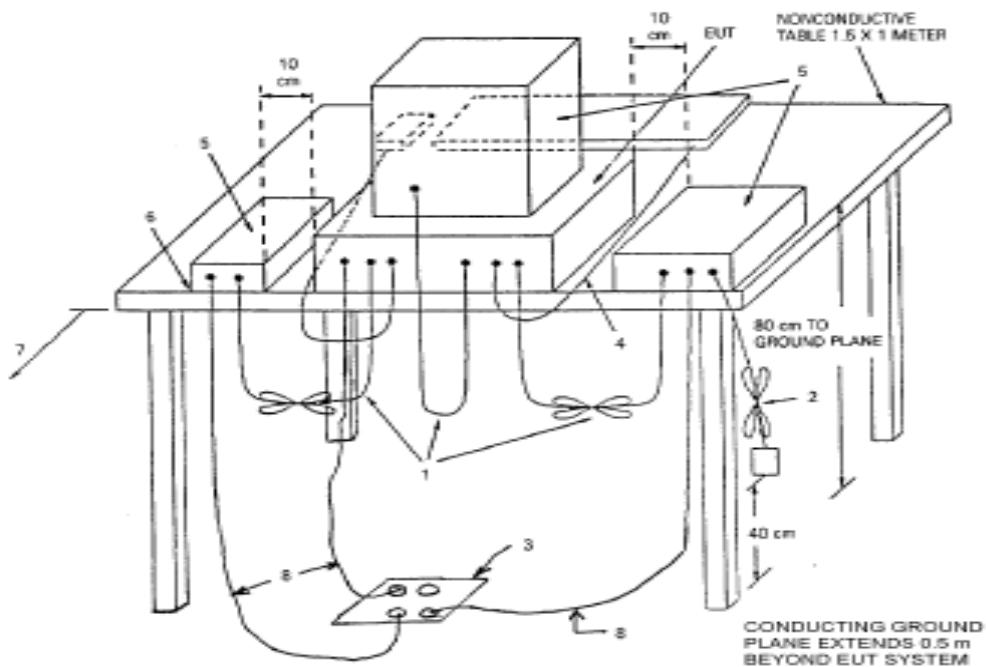
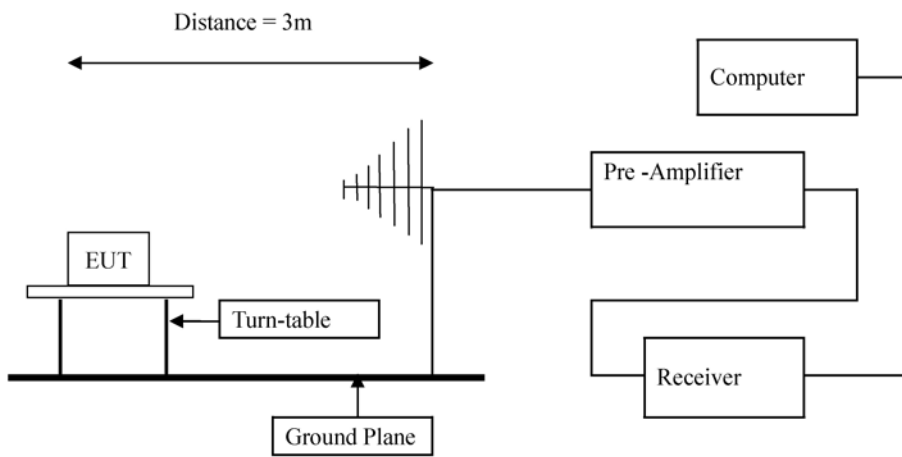



4.3.3 EUT Operating Condition

Operating condition is according to EN 55022:2010

4.3.4 Radiated Emission Limit

All emission from a digital device, including any network of conductors and apparatus connected thereto, shall not exceed the level of field strength specified below:

Frequency Range (MHz)	Distance (m)	Quasi-Peak limits (dB μ V/m)	
		Class A Limits	Class B Limits
30-230	3	50.00	40.00
230-1000	3	57.00	47.00

Note: 1) The lower limit shall apply at the transition frequencies

2) If measurement is not made at 3m distance, then F.S Limitation at 3m distance is adjusted by using the formula $Ld1 = Ld2 * (d2/d1)$

4.3.5 Photo documentation of the test set-up

Please refer to the Section 7

4.3.6 Test Equipment:

Please refer to the Section 2

4.3.7 Test specification:

Environmental conditions: Temperature 24° C Humidity: 46% Atmospheric pressure: 103kPa

4.3.8 Test result

Min. limit margin 3.05dB at 48.011 MHz

The requirements are FULFILLED

Remarks: According to the EN 55022:2010



A. Radiated Emission In Horizontal (30MHz----1000MHz)

EUT Description: BALANCE CHARGER
Operation Mode: VTE600
Tested By: Beryl Zhao
Test date: 2013-10-17

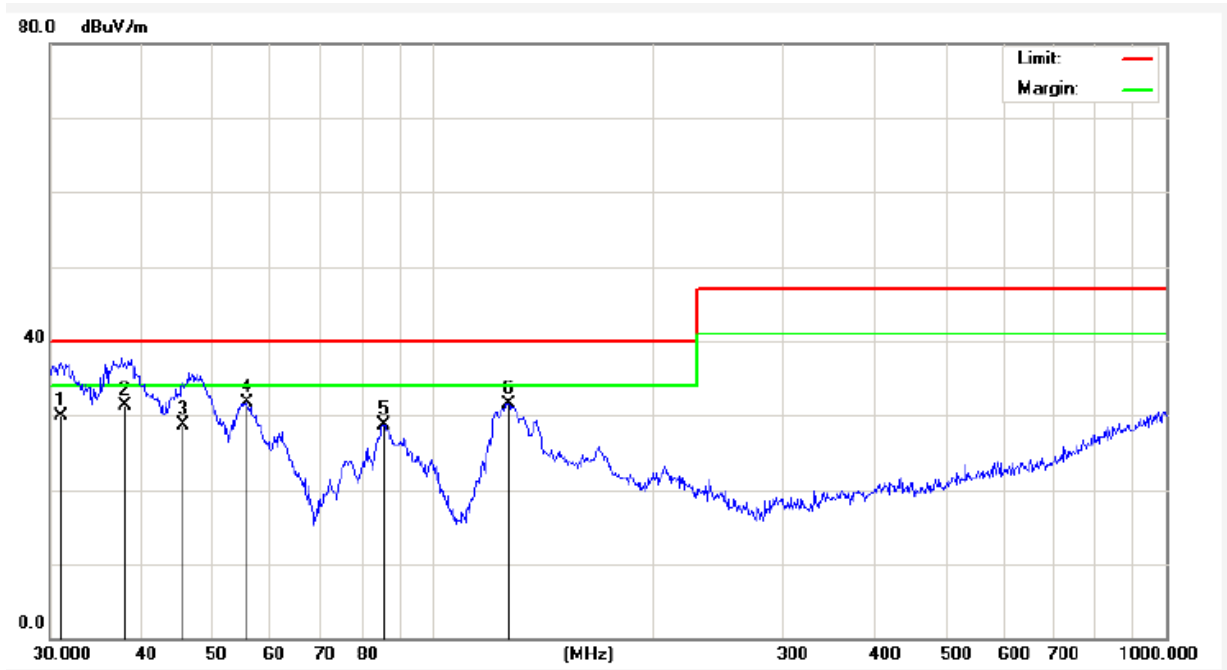

No.	Freq. (MHz)	Reading (dBuV/m)	Factor (dB/m)	Result (dBuV/m)	Limit (dBuV/)	Over Limit (dB)	Detector	Height (cm)	degree (deg)	Remark
1	31.1106	46.77	-16.81	29.96	40.00	-10.04	QP	100	360	
2	37.9098	46.46	-15.18	31.28	40.00	-8.72	QP	100	0	
3	45.6502	42.99	-14.36	28.63	40.00	-11.37	QP	100	360	
4	55.6094	46.75	-14.99	31.76	40.00	-8.24	peak			
5	85.5977	47.00	-18.28	28.72	40.00	-11.28	peak			
6	126.7723	48.92	-17.34	31.58	40.00	-8.42	peak			

-The test data shows much less than the limit, no necessary take down the records.



B. Radiated Emission In Vertical (30MHz----1000MHz)

EUT Description: BALANCE CHARGER
Operation Mode: VTE600
Tested By: Beryl Zhao
Test date: 2013-10-17

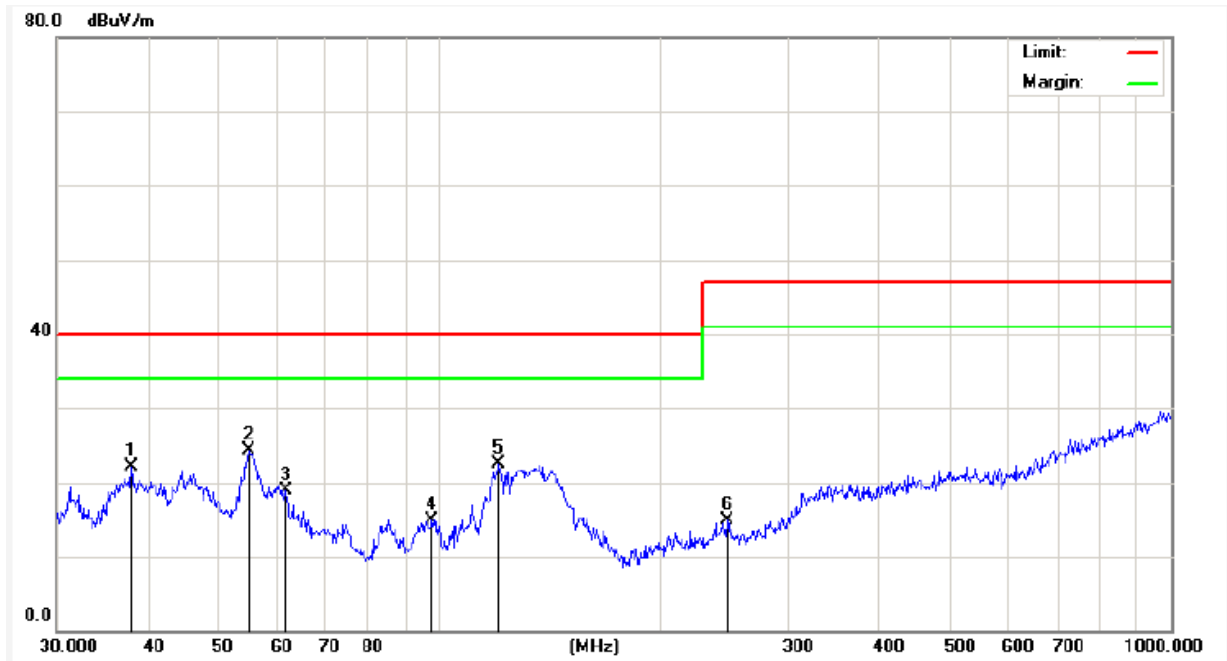

No.	Freq. (MHz)	Reading (dBuV/m)	Factor (dB/m)	Result (dBuV/m)	Limit (dBuV/)	Over Limit (dB)	Detector	Height (cm)	degree (deg)	Remark
1	37.9450	37.32	-15.17	22.15	40.00	-17.85	peak			
2	55.0274	39.29	-14.93	24.36	40.00	-15.64	peak			
3	61.7781	35.08	-16.13	18.95	40.00	-21.05	peak			
4	97.7983	35.87	-20.88	14.99	40.00	-25.01	peak			
5	120.6991	43.87	-21.43	22.44	40.00	-17.56	peak			
6	247.6819	33.34	-18.44	14.90	47.00	-32.10	peak			

4.4 Harmonic Current Emissions

4.4.1 EUT Operating Mode

Running

4.4.2 Block Diagram of Test Setup.

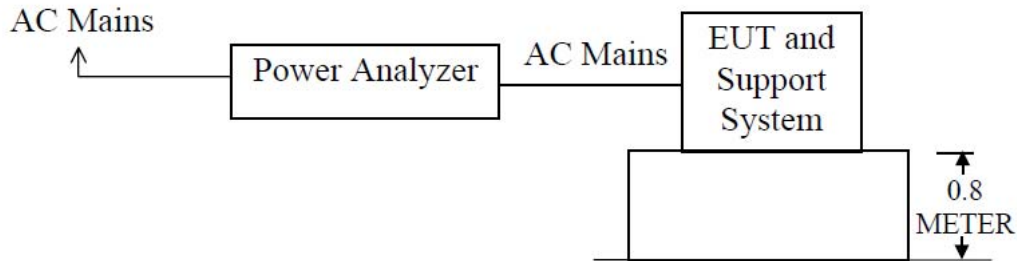

This test was performed as per EMC Basic Standard EN61000-3-2 Class A

4.4.3 Test Equipment

Please refer to Section 2 this report.

4.4.4 Test specification:

Environmental conditions: Temperature: 23° C Humidity: 54% Atmospheric pressure: 103kPa

4.4.5 Results

Port	EUT Operating mode	Result (Passed / Failed)
AC Input	Running	N/A

Note: N/A=Not applicable

4.5 Flicker and Voltage Fluctuation

4.5.1 EUT Operating Mode

Running

4.5.2 Block Diagram of Test Setup.

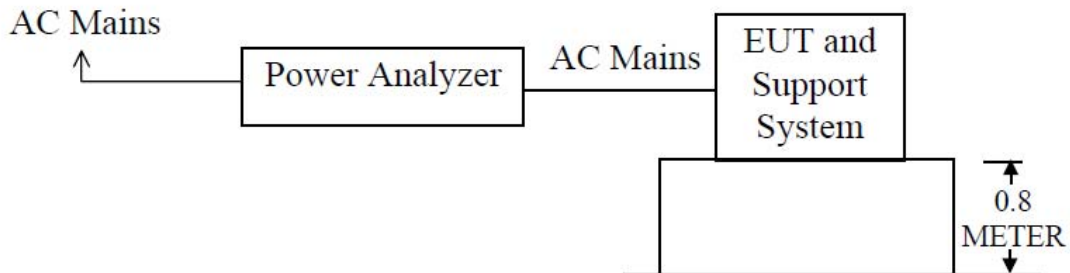

This test was performed as per EMC Basic Standard EN 61000-3-3

4.5.3 Limits of Voltage Fluctuation and Flicks Measurement

Test Item	Limit	Note
P_{st}	1.0	Pst means short-term flicker indicator
P_{lt}	0.65	Plt means long-term flicker indicator
T_{dt} (ms)	200	Tdt means maximum time that dt exceeds 3%.
d_{max} (%)	4	Dmax means maximum relative voltage change.
dc (%)	3	Dc means relative steady-state voltage change.

4.5.4 Test Equipment

Please refer to Section 2 this report.

4.5.5 Test specification:

Environmental conditions: Temperature: 21° C Humidity: 54% Atmospheric pressure: 103kPa

4.5.6 Results

Port	EUT Operating mode or operating mode no.	Result (Passed / Failed)
AC Input	Running	N/A

Note: N/A=Not applicable

5.0 Immunity Test

5.1 Electrostatic Discharge

5.1.1 Schematic of the test

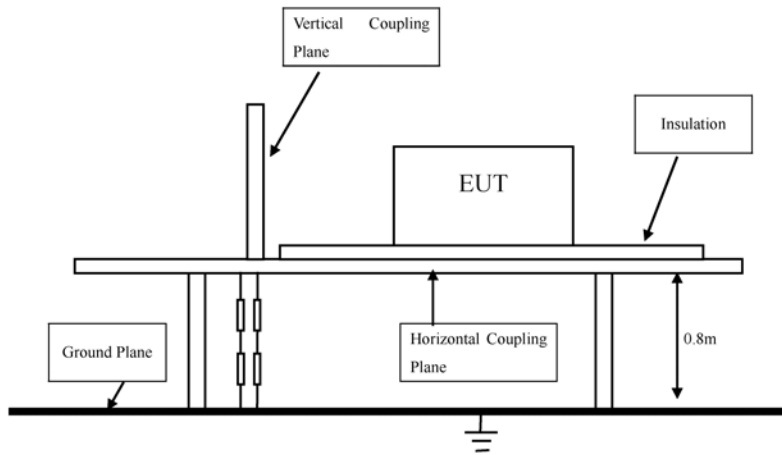

5.1.2 Test method

The test was performed in accordance with EN 61000-4-2

5.1.3 Test severity

±4kV for direct & in-direct Contact Discharge

±8kV for air Discharge

Performance Criterion Require: B

5.1.4 Test Equipment

Please refer to Section 2 this report.

5.1.5 Test specification:

Environmental conditions: Temperature: 21° C Humidity: 54% Atmospheric pressure: 103kPa

5.1.6 Operation mode: Running

5.1.7 Discharge location

- HCP
- VCP
- USB port

5.1.8 Test Result Pass

5.2 RF field strength susceptibility (80MHz----- 1000MHz)

5.2.1 Test Method:

The test was performed in accordance with EN 61000-4-3

Severity: Level 2 (3V/m)

Modulation: 1 KHz 80% AM

Performance Criterion Require: A

Block diagram of Test setup

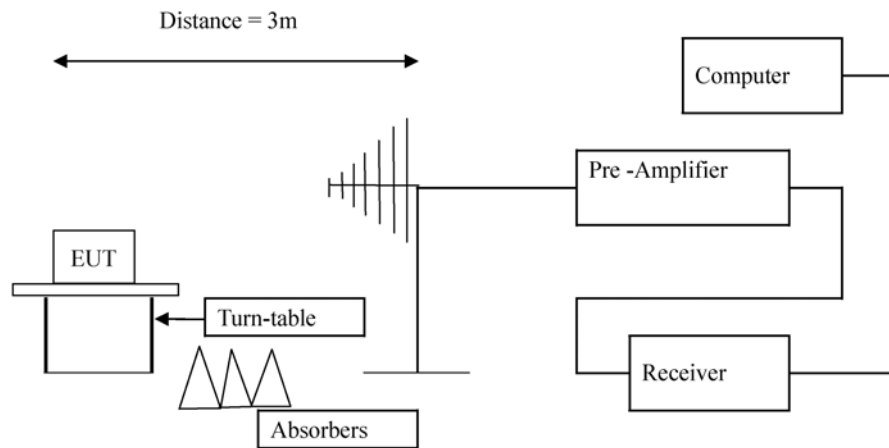

5.2.2 Test Equipment

Please refer to Section 2 this report.

5.2.3 Test specification:

Environmental conditions: Temperature: 25° C Humidity: 45% Atmospheric pressure: 101kPa

5.2.4 Operation mode: Running

5.2.5 Test Result:

Please refer to the following table for individual results.

Frequency (MHz)	Radiation to	Polarity	Level (V/m)	Dwell Time(s)	Sweep Rate (%)	Results
80-1000	Front	Horizontal	3	1	1	Pass
80-1000	Rear	Horizontal	3	1	1	Pass
80-1000	Left	Horizontal	3	1	1	Pass
80-1000	Right	Horizontal	3	1	1	Pass
80-1000	Front	Vertical	3	1	1	Pass
80-1000	Rear	Vertical	3	1	1	Pass
80-1000	Left	Vertical	3	1	1	Pass
80-1000	Right	Vertical	3	1	1	Pass

5.3 Electrical Fast Transient/Burst (EFT/B) immunity test

5.3.1 Schematics of the test



5.3.2 Test Method

The test was performed in accordance with EN 61000-4-4

Severity: Level 2 (1kV)

Performance Criterion Require: **B**

Block diagram of Test setup

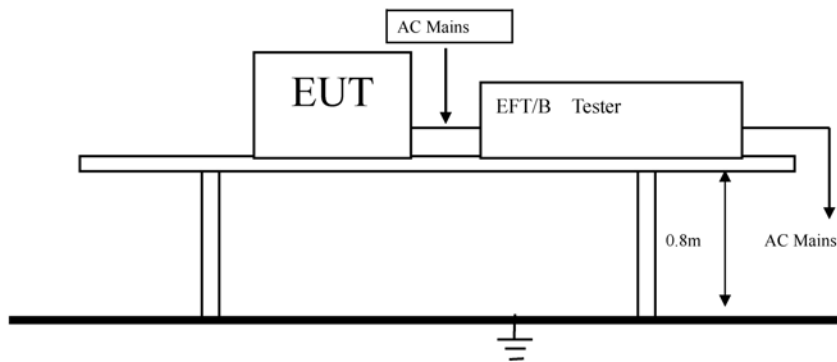

5.3.3 Test Equipment

Please refer to Section 2 this report.

5.3.4 Test specification:

Environmental conditions: Temperature: 21° C Humidity: 54% Atmospheric pressure: 103kPa

5.3.5 Operation mode:

--

5.3.6 Test Results

Inject location: AC mains

Inject Line	Voltage kV	Inject Times (s)	Method	Results
L	±1	120	Direct	N/A
N	±1	120	Direct	N/A
L、N	±1	120	Direct	N/A
E	±1	120	Direct	N/A
L、E	±1	120	Direct	N/A
N、E	±1	120	Direct	N/A
L、N、E	±1	120	Direct	N/A

Note: N/A=Not applicable

5.4 Surge test

5.4.1 Schematics of the test



5.4.2 Test Method:

The test was performed in accordance with EN 61000-4-5

Severity: Level 2

Performance Criterion Require: B

Block diagram of Test setup

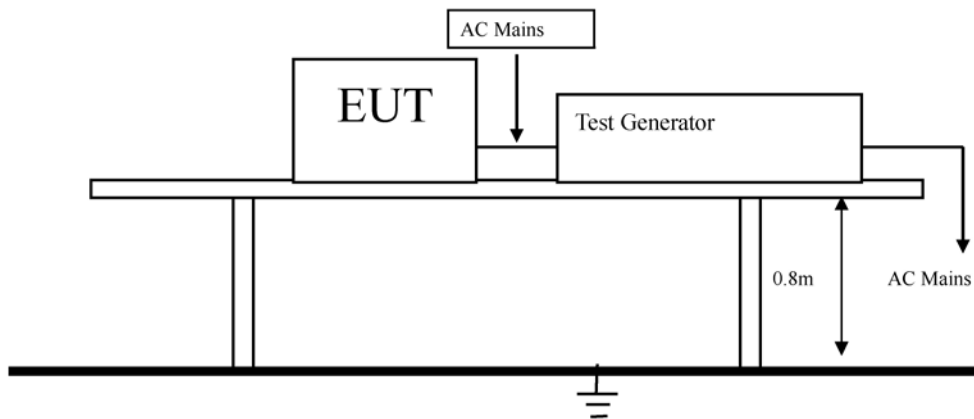

5.4.3 Test Equipment

Please refer to Section 2 this report.

5.4.4 Test specification:

Environmental conditions: Temperature: 22° C Humidity: 53% Atmospheric pressure: 103kPa

5.4.5 Operation mode: --

5.4.6 Test Results

5 pulses for each polarity and test voltage, and repetition rate is 1 per min.

Location	Polarity	0°	90°	180°	270°	Results
L-N	± 1 KV	N/A	N/A.	N/A	N/A	N/A
L-PE	± 2 KV	N/A	N/A	N/A	N/A	N/A
N-PE	± 2 KV	N/A	N/A	N/A	N/A	N/A

Remark: N/A = not applicable.

5.5 Conducted Immunity test

5.5.1 Schematics of the test

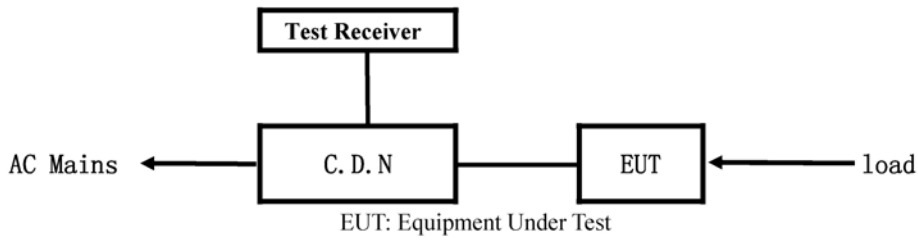

5.5.2 Test Method

The test was performed in accordance with EN 61000-4-6

Severity: Level 2 (3 V rms), 0.15MHz—80MHz

Performance Criterion Require: A

Block diagram of Test setup

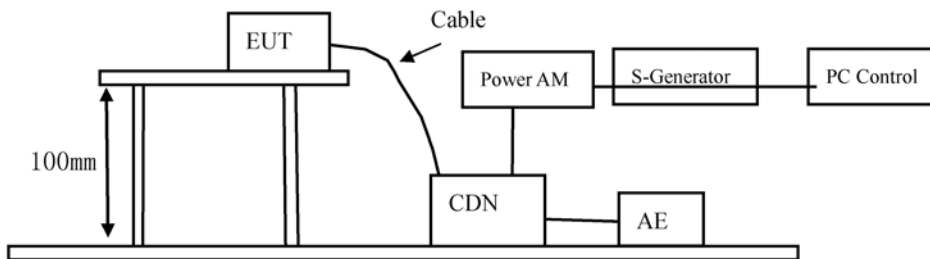

5.5.3 Test Equipment

Please refer to Section 2 this report.

5.5.4 Test specification:

Environmental conditions: Temperature: 23° C Humidity: 52% Atmospheric pressure: 103kPa

5.5.5 Operation mode:

--

5.5.4 Test Results:

Frequency Range (MHz)	Injected Position	Strength	Criterion	Result
0.15 - 80	AC Line	3V (rms) Unmodulated	A	N/A

Note: N/A=Not applicable

5.6 Power-Frequency magnetic field test

5.6.1 Schematics of the test



5.6.2 Test Method

The test was performed in accordance with EN 61000-4-8

Severity: Level 1 (1A/m),

Performance Criterion Require: A

Block diagram of Test setup

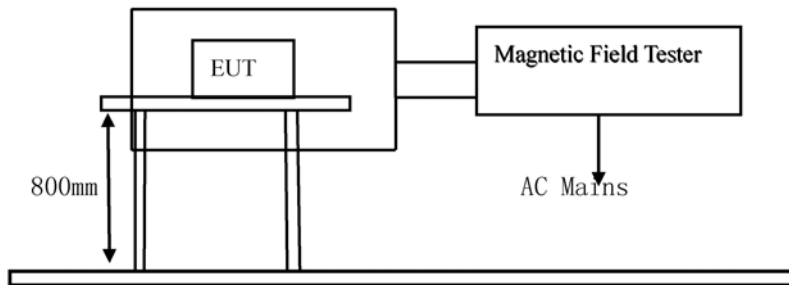

5.6.3 Test Equipment

Please refer to Section 2 this report.

5.6.4 Test specification:

Environmental conditions: Temperature: 21° C Humidity: 54% Atmospheric pressure: 103kPa

5.6.5 Operation mode: --

5.6.6 Test Results:

Test Level	Testing Duration	Coil Orientation	Criterion	Result
1A/m	5 Mins	X	A	N/A
1A/m	5 Mins	Y	A	N/A
1A/m	5 Mins	Z	A	N/A

Note: N/A=Not applicable

5.7 Voltage Dips/Interruptions immunity test

5.7.1 Schematics of the test



5.7.2 Test Method:

The test was performed in accordance with EN 61000-4-11:2004

Performance Criterion Require: C&B

Block diagram of Test setup

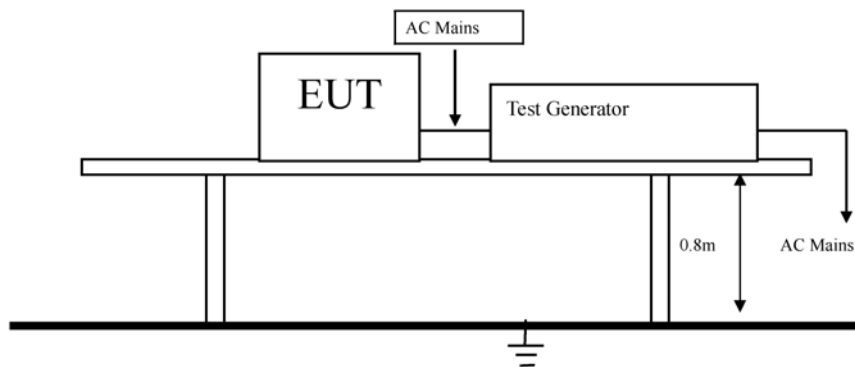

5.7.3 Test Equipment

Please refer to Section 2 this report.

5.7.4 Test specification:

Environmental conditions: Temperature: 22° C Humidity: 55% Atmospheric pressure: 103kPa

5.7.5 Operation mode: --

5.7.4 Test Result:

Voltage Dip: Voltage Interceptions:

Test Level % Ut	Reduction	Duration (periods)	Phase Angle	Meet Criterion	Result
0	100	0.5	0° - 360°	B	N/A
70	30	25	0° - 360°	C	N/A

Test Level % Ut	Reduction	Duration (periods)	Phase Angle	Meet Criterion	Result
0	100	250	0° - 360°	C	N/A

Note: N/A=Not applicable



6.0 CE Label

6.1 label specification

Text of the mark is black or white in color and is left justified. Labels are printed in indelible ink on permanent adhesive backing and shall be affixed at a conspicuous location on the EUT or silk-screened onto the EUT.



6.2 Mark Location: On the product body



7.0 Photos of testing

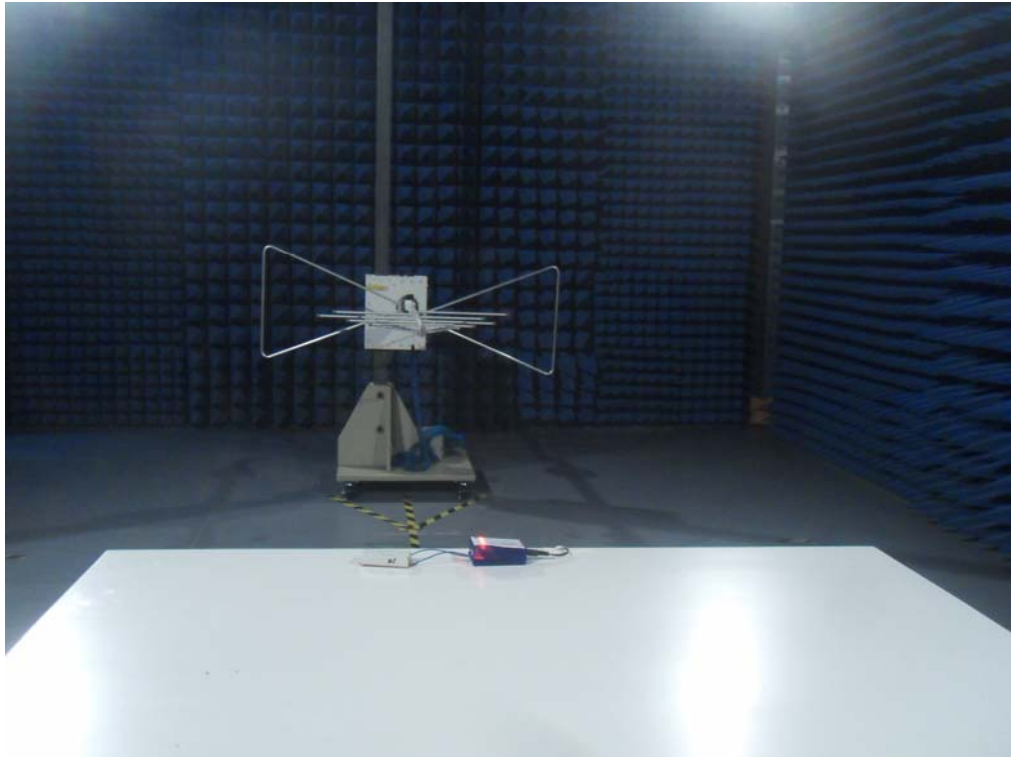

8.0 Appendix:

Photos of the Product

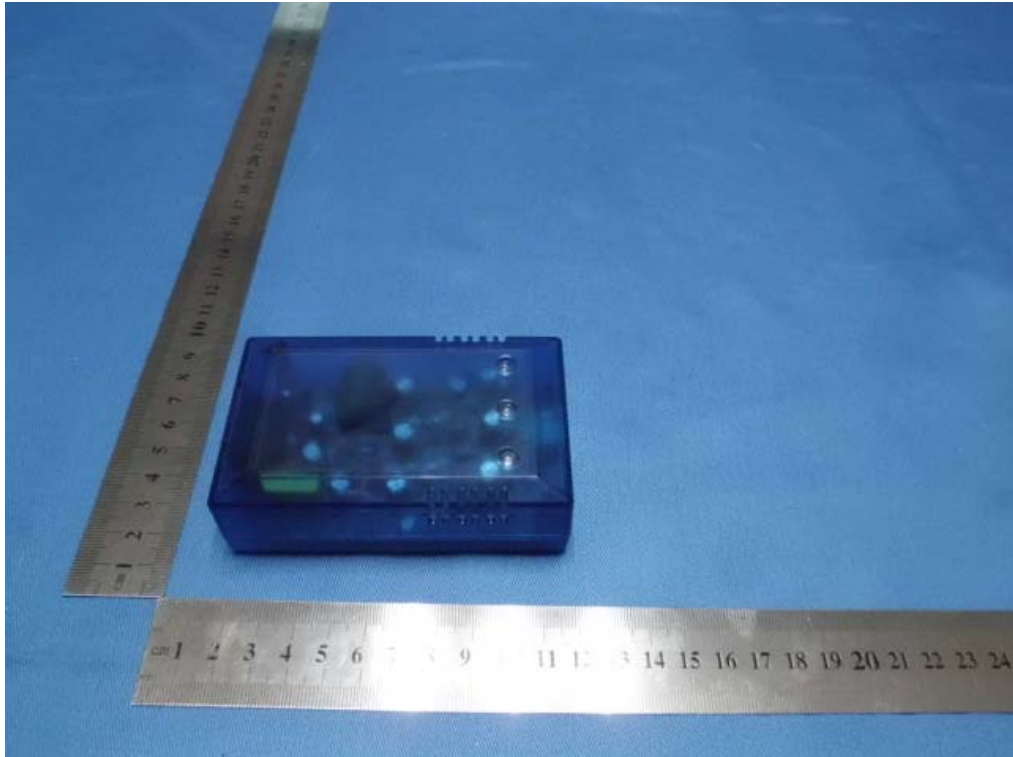

--End of the report--