

Chemistry System	MnO <sub>2</sub> /Li:Manganese Dioxide (CR)	
<b>Nominal Voltage</b>	3.0 V	
<b>Capacity</b>	70mAh	<b>Condition</b> discharge at 0.1mA 2.0V end discharge voltage ambient temperature 25 °C
<b>Volume</b>	approx. $\Phi$ 16.0x2.0mm	
<b>Weight</b>	approx. 1.3g	
<b>Self-Discharge Rate</b>	<3%	after 1 year storage at 25 °C
<b>Operating Temperature</b>	-30...60 °C -22...+140F	

Discharge Characteristics on Load

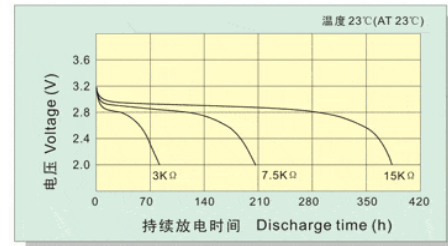

Discharge Characteristics on Temperature

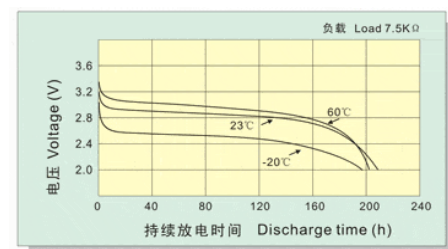

**Features:**

- High voltage of 3 volts - twice that of conventional dry batteries
- Extremely small self-discharge for long service and shelf life
- A wide operational temperature range
- Compact and lightweight; extremely high energy density per unit weight
- Very safe (poly-carbonmonofluoride lithium)
- Extremely strong load pulse characteristics (manganese dioxide lithium)

**Applications:**

- Calculators
- Cameras
- Compact, low power consuming cordless applications
- Electronic translators
- Electronic watches (digital and analog)
- Memory back-up in all types of devices (with tab terminals)

**mechanical specifications**

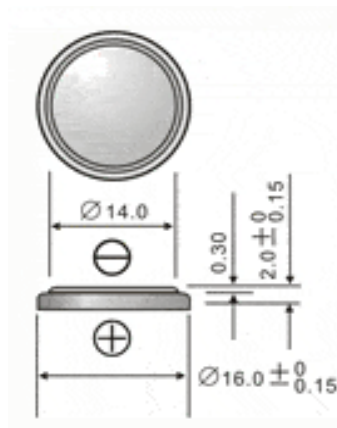

Chemical	LiMnO <sub>2</sub>
Type	CR1620
DRAWN BY / DATE	Herry Li/2009/05/30

Manufacturer reserves the right to alter or amend the design, model and specification without prior notice.