

Chemistry System	MnO ₂ /Li:Manganese Dioxide (CR)	
Nominal Voltage	3.0 V	Condition discharge at 0.5mA 2.0V end discharge voltage ambient temperature 25 °C
Capacity	270mAh	
Volume	approx. Φ 24.5x3.0mm	
Weight	approx. 4.3g	
Self-Discharge Rate	<3%	after 1 year storage at 25 °C
Operating Temperature	-30...60 °C -22...+140F	

Discharge Characteristics on Load

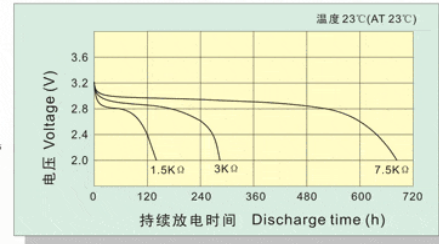

Discharge Characteristics on Temperature

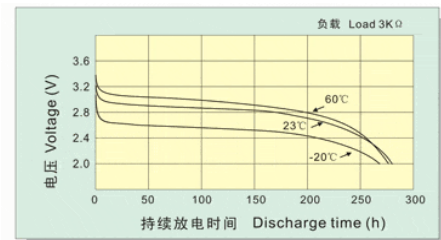

Features:

- High voltage of 3 volts - twice that of conventional dry batteries
- Extremely small self-discharge for long service and shelf life
- A wide operational temperature range
- Compact and lightweight; extremely high energy density per unit weight
- Very safe (poly-carbonmonofluoride lithium)
- Extremely strong load pulse characteristics (manganese dioxide lithium)

Applications:

- Calculators
- Cameras
- Compact, low power consuming cordless applications
- Electronic translators
- Electronic watches (digital and analog)
- Memory back-up in all types of devices (with tab terminals)

mechanical specifications

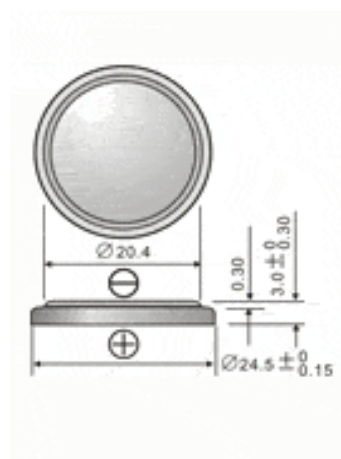

Chemical	LiMnO ₂
Type	CR2430
DRAWN BY / DATE	Herry Li/2009/05/30

Manufacturer reserves the right to alter or amend the design, model and specification without prior notice.